

# FURLEX

*electric*



 **SELDÉN**  
*for sailing*

**Furlex has been making life on board easier for decades. In fact, Furlex is the best-selling headsail furler in the world. Once you have experienced using a Furlex you will not want anything else up front. And now there is a new Furlex that will make life on board even easier. Lean back and enjoy Furlex Electric.**



## **All the power you need**

Furlex Electric is available as a complete kit or as an upgrade kit for an existing Furlex 200S, 300S, 204S and 304S series. The push-button function of a Furlex Electric makes pulling on the furling line a thing of the past.

## **Reliable performance**

Furlex Electric is designed around a highly efficient 48V electric motor. A DC/DC converter is included and converts the boat's 12V or 24V to 48V which allows for thin cables to the motor unit, easy installation and a compact unit design. Power is transmitted to a self-locking worm gear to rotate the luff extrusion at a max torque of 60Nm (204E) and 90Nm (304E). These high torque levels mean that you can always rely on being able to furl your foresail – even when the wind and sea are doing their worst.

*Electric furling mast in combination with Furlex electric. Flexible, convenient and safe.*



The motor uses only 10-25 amps at normal load and it takes 25-30 seconds to furl a genoa. When sailing with a partly reefed genoa, the worm drive provides a mechanical lock. In order to prevent accidental overloading, the system comes with a built-in current limiter adapted to the type of Furlex, 204E or 304E. If you attempt to furl the sail without first releasing the sheet, the torque is immediately limited to a safe level. This safety feature is automatically re-set a few seconds after the control switch is released.

In the event of power failure, the sail is simple to furl manually. An emergency line-driver system is included as standard and can be used for both on-deck and through-deck installations. An emergency handle with 1/2" socket is available as an option.







## Two speed function

Press one button and you will run the sail, in or out, at low speed. To double the speed, press the other button simultaneously.

## On-deck or through-deck. The choice is yours

Furlex Electric is available for either on-deck or through-deck installations. The main advantage of a through-deck installation is better sailing performance as a result of a longer luff length. More space on the foredeck is an added bonus!



## On the technical side

The 48V brushless motor connects to a gear box and a steel/bronze worm gear, transmitting the torque to the luff extrusion with a gear ratio of 122:1 (emergency furling 40:1). The motor and primary gear box are packed in oil in a hermetically sealed inner compartment and all units are pressure tested during assembly. This makes for a compact design, a highly efficient transmission and a failsafe function.

Nothing is left aside.





## Upgrade your manual Furlex

Push-button performance is an easy upgrade for anyone who already has a manual Furlex 200S or 300S series (production year 1997-2015) or the current models 204S or 304S on their yacht. The furling line, drum and line guard assembly are simply replaced with a Furlex Electric motor unit. No sail conversion is required as the luff length of your existing sail is unaffected.

### Converting Furlex 200S/300S to Furlex Electric



### Converting Furlex 204S/304S to Furlex Electric



*Heavy-duty toggle to withstand torsional loads. An extension link is available to provide anchor clearance.*



*In case of power failure, Furlex Electric can be operated manually.*

*Weather proof composite outer shell for rugged reliability and long service life.*



# Furlex Electric specifications

Type	Forestay diameter mm	L mm	HW mm	W2 mm	D2 diam. mm	H2 mm
204E	6	180	175	12	10,5	-16
	7	180	175	14	12,5	-16
	8	183	175	14	14,5	-7
304E	8	192	175	14	14,5	23
	10	191	175	16	16,5	21,5

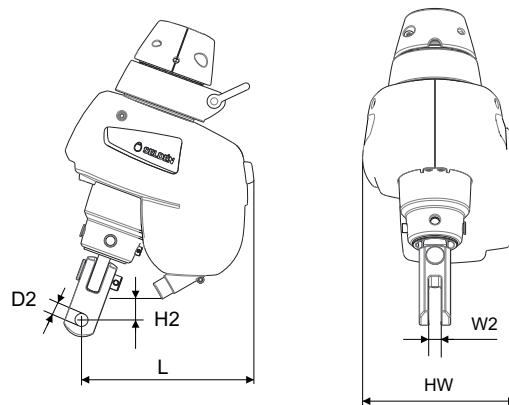

## Furlex Electric assemblies (excl. control pack)

Type	Forestay diameter mm	Max. forestay length, mm	Wire termination, three options						Control pack
			Standard Sta-lok wire terminal,	Rigging screw and Sta-lok wire terminal,	Swaged terminal,	TDE version (Through-Deck) with Sta-lok,	TDE version (Through-Deck) with rigging screw,	Swaged terminal,	
			Art. No. 12V/24	Art. No. 12V/24	Art. No. 12V/24	Art. No. 12V/24	Art. No. 12V/24	Art. No. 12V/24	
204E	6	10600	035-025-101	035-025-111	035-025-121	035-025-131	035-025-141	035-025-151	For Genoa: 532-815-90
	6	13000	035-025-102	035-025-112	035-025-122	035-025-132	035-025-142	035-025-152	
	6	15400	035-025-103	035-025-113	035-025-123	035-025-133	035-025-143	035-025-153	
	For Cutter 532-815-91	7	13000	035-025-104	035-025-114	035-025-124	035-025-134	035-025-144	035-025-154
		7	15400	035-025-105	035-025-115	035-025-125	035-025-135	035-025-145	035-025-155
		7	17800	035-025-106	035-025-116	035-025-126	035-025-136	035-025-146	035-025-156
		8	15400	035-025-107	035-025-117	035-025-127	035-025-137	035-025-147	035-025-157
		8	17800	035-025-108	035-025-118	035-025-128	035-025-138	035-025-148	035-025-158
304E		8	15500	042-031-101	042-031-111	042-031-121	042-031-131	042-031-141	042-031-151
	8	17900	042-031-102	042-031-112	042-031-122	042-031-132	042-031-142	042-031-152	
	10	15500	042-031-103	042-031-113	042-031-123	042-031-133	042-031-143	042-031-153	For Cutter 532-815-93
	10	17900	042-031-104	042-031-114	042-031-124	042-031-134	042-031-144	042-031-154	
	10	20300	042-031-105	042-031-115	042-031-125	042-031-135	042-031-145	042-031-155	

### Control pack includes:

Motor Control Unit, Connection Box, Control Buttons, Connection cables.

Additional parts needed for the Seldén Power Supply and SEL-Bus system are listed in 597-283-E Order guide.

Type	Forestay diameter mm	Retro-fit installation kit excl. control pack		Control pack Art. No.
		Type S → E Art. No. 12V/24V	Type TD → TDE Art. No. 12V/24V	
200	6	549-601-200	549-601-225	For Genoa: 532-815-90
	7	549-601-205	549-601-225	
	8	549-601-210	549-601-225	For Cutter 532-815-91
204	6	549-601-250	549-601-275	
	7	549-601-255	549-601-275	
	8	549-601-260	549-601-275	
300	8	549-601-215	549-601-240	For Genoa: 532-815-92
	10	549-601-220	549-601-240	
304	8	549-601-265	549-601-290	For Cutter 532-815-93
	10	549-601-270	549-601-290	

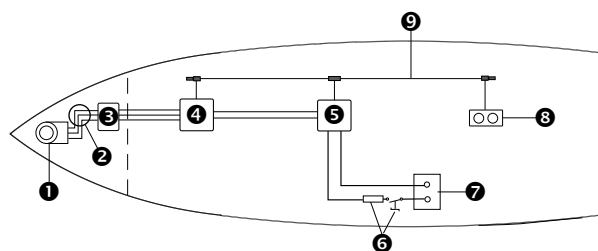

1. Furlex Electric
2. Deck gland
3. Connecting box
4. Motor control unit
5. Power supply unit
6. Main switch/fuse
7. Battery 12/24V
8. Control buttons
9. SEL-Bus system

Optional items	Art. No.
Emergency handle (1/2" socket)	533-922
Ø6/7 mm eye/fork extension link, L=90 mm	517-115-01
Ø8/10 mm eye/fork extension link, L=130 mm	517-116-01

For further technical information, please see our instructions for installation, [www.seldenmast.com](http://www.seldenmast.com)

# DINGHIESKEELBOATSYACHTS

**Seldén Mast AB, Sweden**  
Tel +46 (0)31 69 69 00  
e-mail [info@seldenmast.com](mailto:info@seldenmast.com)

**Seldén Mast Limited, UK**  
Tel +44 (0)1329 50 40 00  
e-mail [info@seldenmast.co.uk](mailto:info@seldenmast.co.uk)

**Seldén Mast Inc., USA**  
Tel +1 843-760-6278  
e-mail [info@seldenus.com](mailto:info@seldenus.com)

**Seldén Mast A/S, Denmark**  
Tel +45 39 18 44 00  
e-mail [info@seldenmast.dk](mailto:info@seldenmast.dk)

**Seldén Mid Europe B.V.,  
Netherlands**  
Tel +31 (0)111-698 120  
e-mail [info@seldenmast.nl](mailto:info@seldenmast.nl)

**Seldén Mast SAS, France**  
Tel +33 (0)251 362 110  
e-mail [info@seldenmast.fr](mailto:info@seldenmast.fr)

**Seldén Mast Asia Ltd,  
Hong Kong**  
Tel +852 3572 0613  
e-mail [info@seldenmast.com.hk](mailto:info@seldenmast.com.hk)

[www.seldenmast.com](http://www.seldenmast.com)

The Seldén Group is the world's leading manufacturer of mast and rigging systems in carbon and aluminium for dinghies, keelboats and yachts.

Our well known brands are Seldén and Furlex. The worldwide success of Furlex has enabled us to build a network of over 750 authorised dealers covering the world's marine markets. So wherever you sail, you can be sure of fast access to our service, spare parts and know-how.

SELDÉN and FURLEX are registered trademarks of Seldén Mast AB.