

GAFF LOCK 2T5 SWL

GAFF LOCK 4T SWL

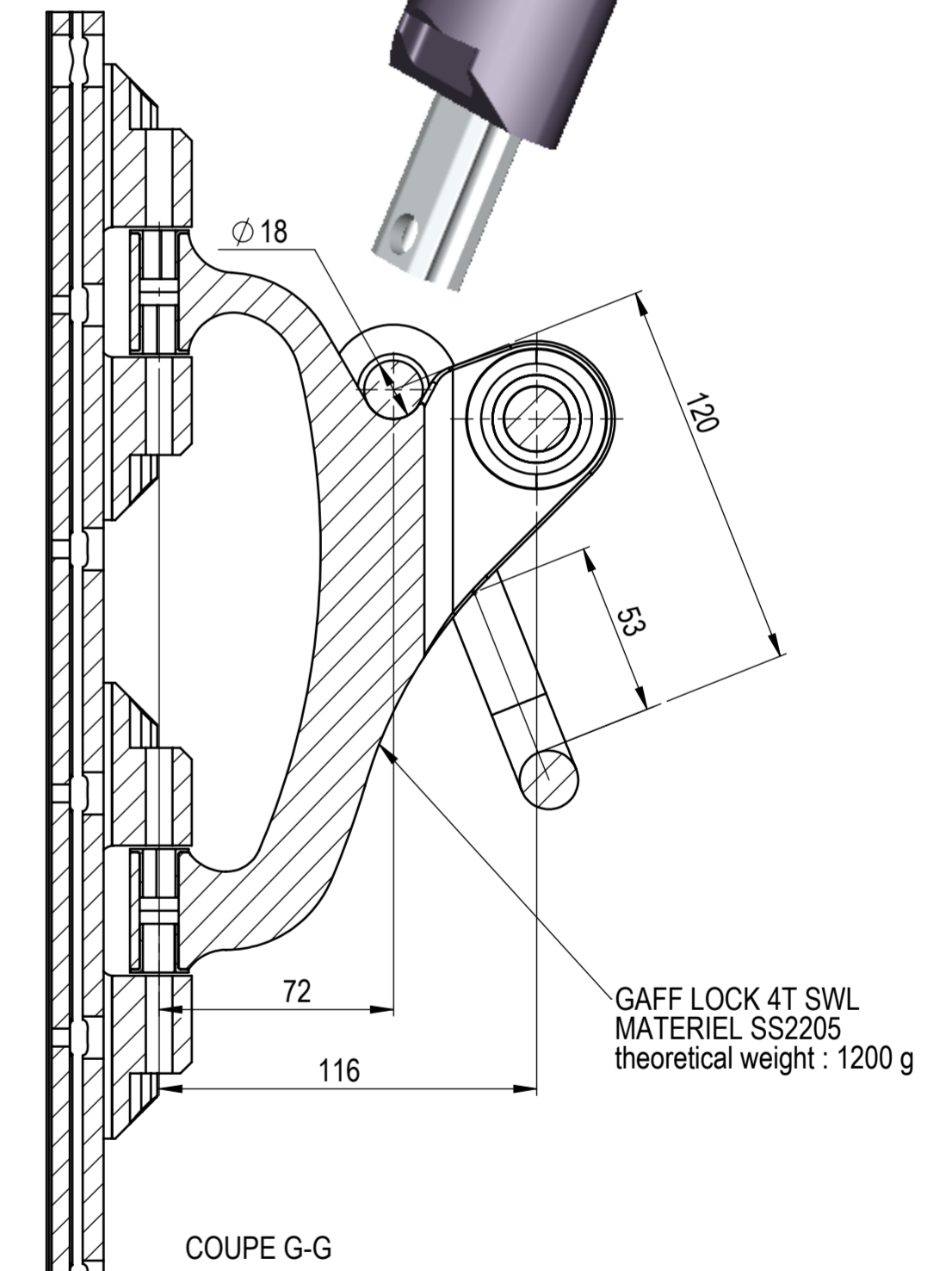
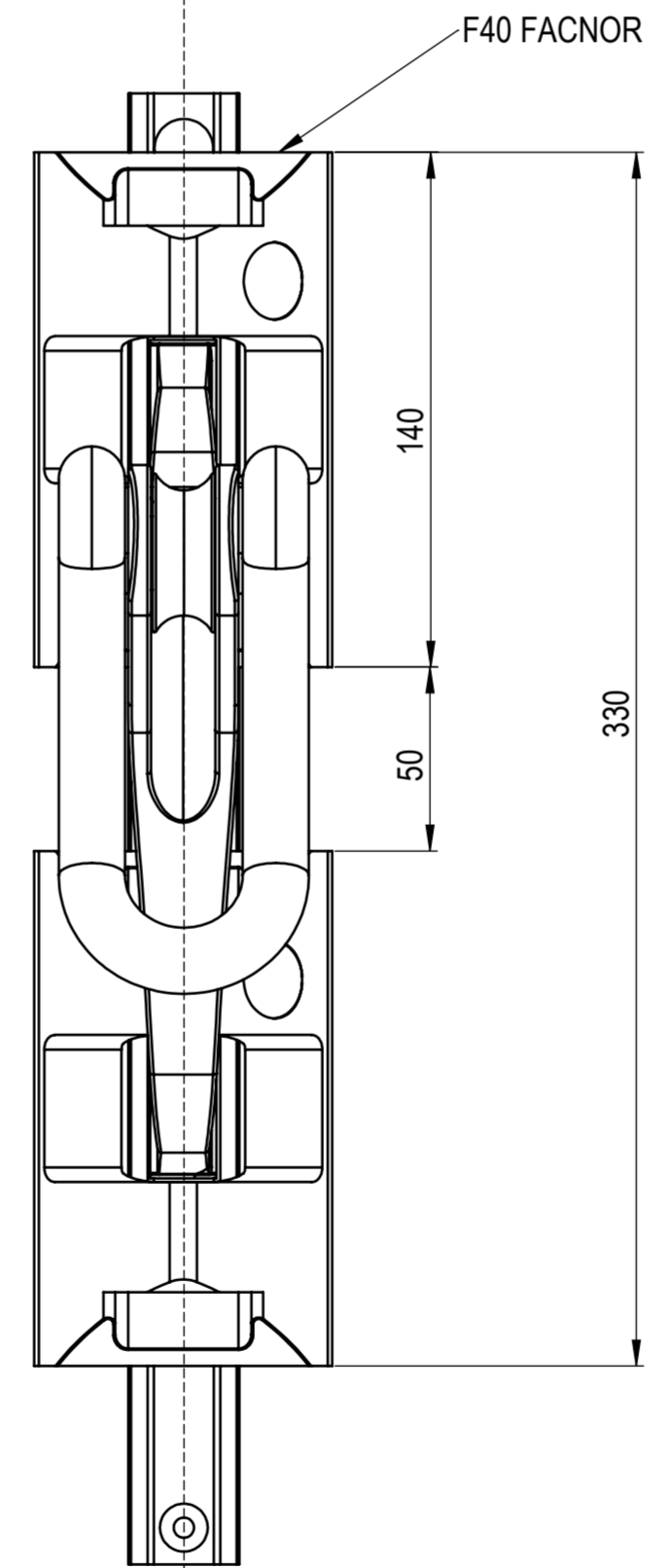
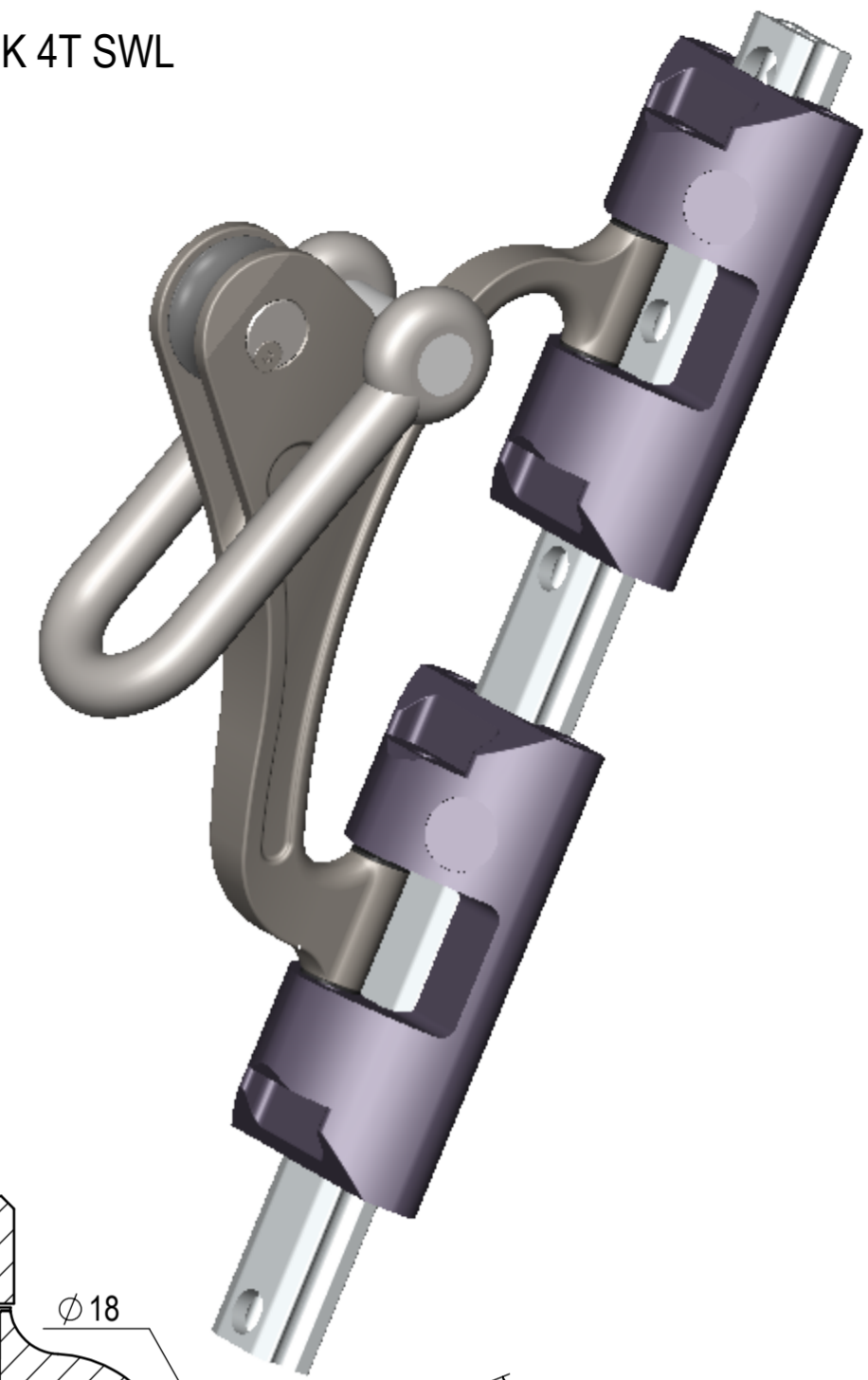
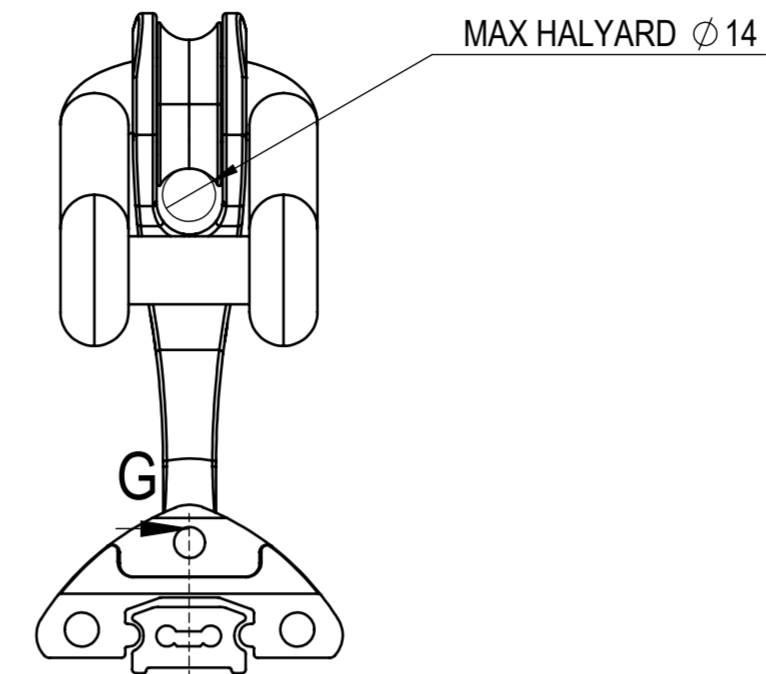
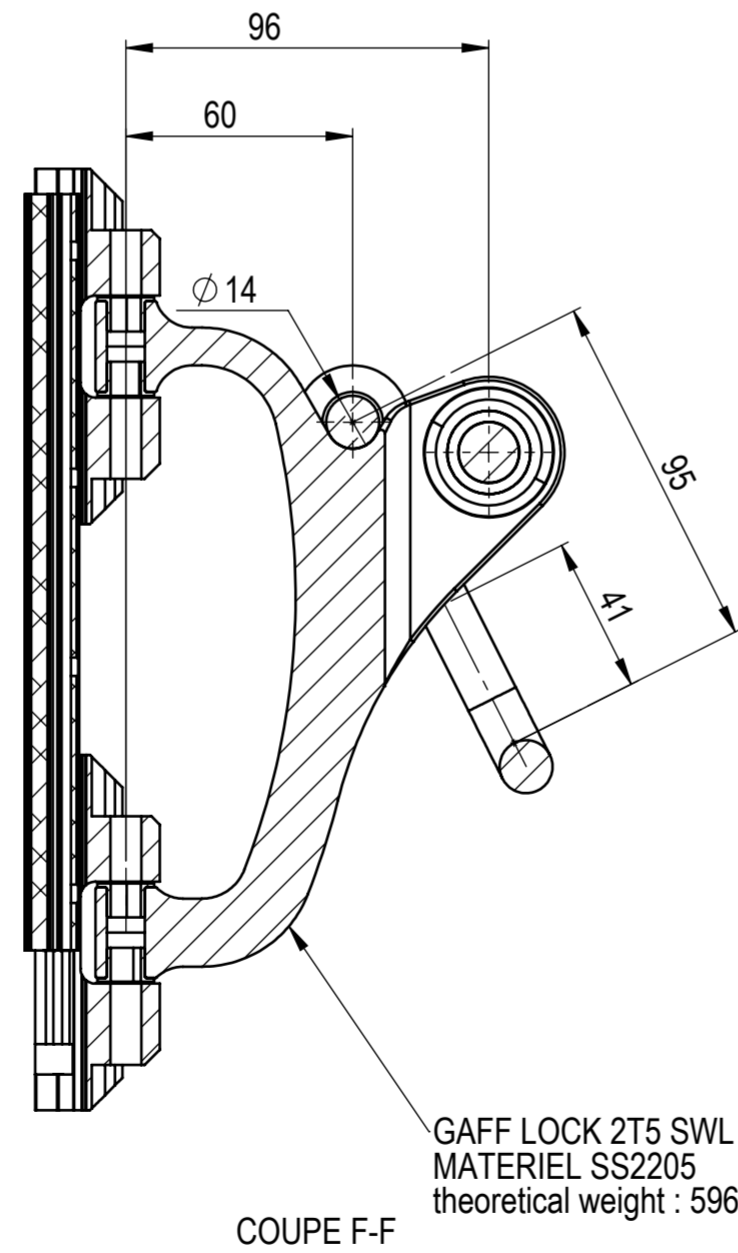
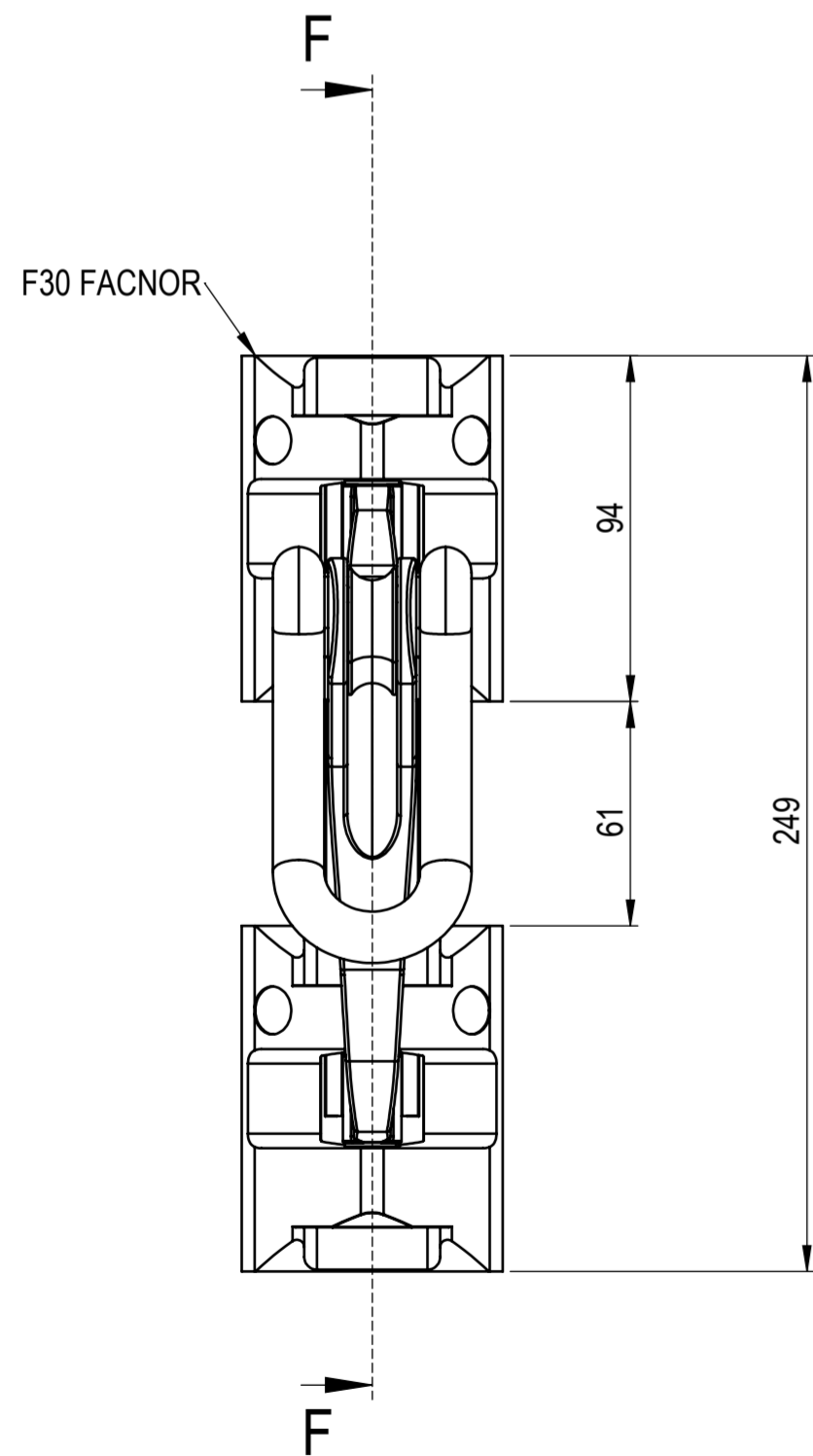
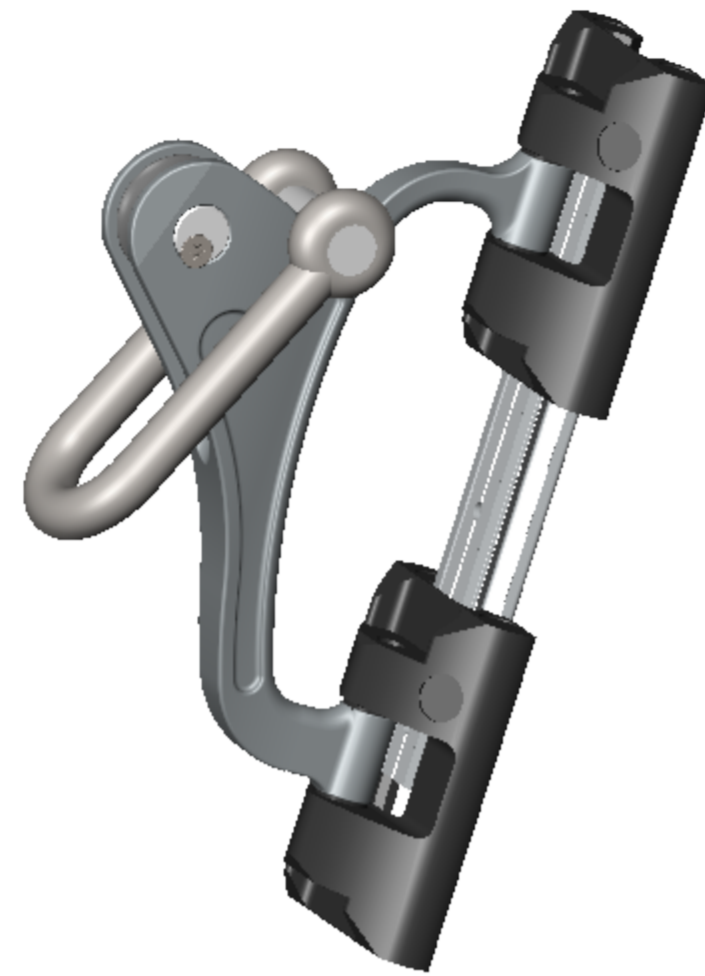
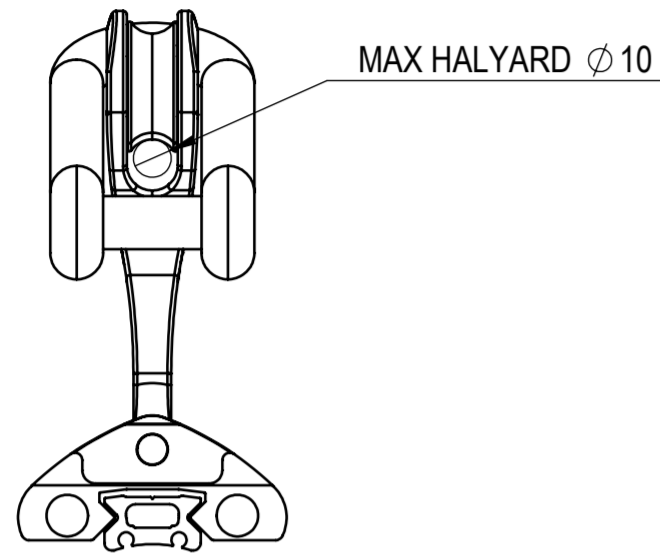

REV.	DATE	DE AUTEUR	APPROUVE	WEIGHT DATA UPDATE	DESCRIPTION
A	06/02/2020	DE			
GAFF LOCK RANGE V3					<p>FACNOR S.A. Z.A. 10, Rue du Pont des Bernes F-50550 SAINT-VAAST-LA-HOUGUE tel. +33 (0)2 33 33 60 22 fax. +33 (0)2 33 23 14 27</p>
Matière: x					<p>Ech: 1:2 A2</p> <p>Indice: A</p>
Etat Final: x					<p>Ce plan est la propriété intellectuelle FACNOR SA. Il ne peut être divulgué à des tiers sans notre autorisation écrite, ni servir à d'autres fabrications.</p>
Auteur: DEtheve					<p>Il est impératif de tenir compte des consignes mentionnées sur le document 29000000000 joint à la commande.</p>
Date: 04/02/2020					<p>Please, do make sure to apply the instructions as specified on the document 29000000000 attached to the order.</p>
Tol.Gén.: ISO 2768-mK					<p>Ra.Gén.: $\sqrt{Ra\ 1,6}$ ($\sqrt{1}$)</p>
Etude: 04022020DE01					